

JOURNAL OF THE  
BRITISH SOCIETY OF DOWSERS  
No. 3 March, 1934

NOTICES

IT is proposed to hold the Congress of the Society on Friday and Saturday, **June 1st** and **2nd**: lectures and discussions in a hall in London on the first day and practical tests at Lindfield on the second day.

Members who are likely to attend either or both days are requested to inform the Secretary by May 1st; details of the arrangements will be sent to them when the approximate numbers are known.

It may be necessary to make a small charge to cover the hire of the hall and other minor expenses. It would give Colonel and Mrs. Bell pleasure if members attending on the second day would be their guests for lunch and tea.

\* \* \* \* \*

At the meeting at 12 Park Crescent on December 7th Dr. Dudley Wright gave a short lecture on the application of dowsing to the diagnosis of disease.

By the kindness of Dr. Munro, another meeting will be held on Thursday, **April 5th**, from 4 to 6.

\* \* \* \* \*

A letter expressing good wishes for the prosperity of our Society has been received from L'Association Française et Internationale des Amis de la Radiesthésie. Copies of our *Journal* will be sent to L'Association and also to La Société de Radiesthésie du Languedoc.

\* \* \* \* \*

Dr. Jules Regnault, former surgeon of naval hospitals and ex-professor of anatomy, who has made a special study of radiation, has sent us four copies of the magazine he edits called *La Côte d'Azur Médicale*, a monthly review dealing with radiation. He has also sent us a copy of *Le Petit Sourcier*, a monthly journal dealing with hydrological research, and copies of *La Radio-Tellurie*, and *Organismes considérés comme des oscillateurs-résonateurs polarisés*, and an account of the International Congress at Avignon in 1932. We hope to give more information on these publications in our next number.

\* \* \* \* \*

An example of the psychic aspect of dowsing referred to in the Editorial of our first number is given in 'Correspondence'.

\* \* \* \* \*

Herr Hans Falkinger, the author of the interesting little book *Die Wünschelrute*, included in the list at the end of the *Journal*, has sent us some notes on dowsing operations carried out by him since 1923, together with the names and addresses of his clients. In many cases the results were not reported to him, but he knows of only five failures.

His locations of water include three springs for Weikersdorf Parish, in Steinfeld, Lower Austria, an artesian hot spring in Perchtoldsdorf 12 metres deep, and twenty-three other locations at depths varying from 1 to 15.8 metres.

As regards minerals, during three weeks in 1928 he prospected for coal between Bonn and Krefeld on behalf of the firm of Raky, of Salsgitter. The coalfield was opened up by 150 boreholes averaging 600 metres in depth. Good results have been obtained of late years by the Raky Co. in districts where he prospected, such as Nienhagen, Oberg, Edesse, and the firm sold the Berkhöpen field, near Peine, where he had carried out prospectations, for eight million reichsmark.

He was asked to examine twelve borings for oil in Germany and reported favourably on them.

For three months in 1928 he prospected successfully for bauxite in Yugoslavia.

On October 4th, 1928, he dowsed for the first Austrian petroleum well at Zisterdorf, Lower Austria, giving a depth of 550 metres for the first trace of oil, the actual depth being 530 metres.

\* \* \* \* \*

Herr Falkinger, whose address is: Vienna XIII, Spiegelgrundstrasse 29, would like to exchange with members photos showing how they hold the rod.

\* \* \* \* \*

Whalebone for divining rods can be obtained cut to size from Messrs. Devine and Co., Ltd., St. Stephens Road, London, E.3.

\* \* \* \* \*

*Erratum*: In the December *Journal*, Page 39, Line 11 from end, W. E. Pogson should be W. N. Pogson.

\* \* \* \* \*

Communications for the Editor and enquiries should be sent to Colonel A. H. Bell, Backwoods, Lindfield, Sussex.

\* \* \* \* \*

## SOME OBSERVATIONS ON THE MOVEMENTS OF THE ROD AND PENDULUM IN DOWSING

By J. A. SIMPSON EMSLIE, M.B., Ch.B.

IT is believed by a great number of people, including many who practise the art of dowsing, that the power of locating water and other substances is very largely due to the rod or pendulum which they are using. They believe that it is the rod which picks up the 'radiations' and that it is the rod which causes their hands to rise. Now in reality it is exactly the other way about; muscular contraction of the flexors of the forearm is what causes the rod to rise. The rod and also the pendulum is nothing more or less than an indicator of muscular movement. It was once thought that broom or hazel twigs had peculiar powers, but we now know that many other substances will do equally as well, such as whalebone and pieces of wire; in fact, it is not necessary to use a rod or pendulum at all. Many dowsers can find the presence of water and metals purely by the muscular contractions of their flexors alone. By using a rod, however, the very smallest muscular movement is registered in an exaggerated way, and so the phenomenon is noted more easily. The more flexible the rod, the better an indicator will it be, owing to the fact that it acts as a spring when held in the two hands. This is why all rods, no matter what material, are of the V shape. Thus the flexibility and springiness of whalebone make it particularly suitable and it is now being used by many dowsers.

Considering that the action is a muscular one, let us now study it more closely. When we walk over water our hands flex at the wrist, causing the rod to rise. The movement that has taken place is involuntary; that is, it is not under the control of the will, we do not put the rod up consciously, the contraction that takes place is one that requires no mental effort on our part. It is the influence of the water that has caused the action. The movement is purely a reflex action.

Our whole body is made up of reflexes; the very act of standing calls into action many reflexes. To give the simplest example of a reflex—if you put your fingers on a hot surface you involuntarily draw them away—before you are actually conscious of the heat. What has happened is that a message has passed from the skin along the sensory nerves to the spinal cord. In the cord the message is transmitted to another set of nerves, the motor nerves, which convey the message to the muscles, causing them to contract and so remove the part from danger. These messages travel with extreme rapidity and you have withdrawn your hand

before the pain is felt. The action, then, is like an arc. Skin to spinal cord and back to muscle. Messages may travel to and fro, if they are small ones, without going to the brain at all, so that we are unconscious of them.

The movements of the rod and pendulum are of the same nature—reflex actions. What else can these movements be if they are involuntary? Tonic innervation, perhaps? An increase in the tone? Yes, but that is also reflex. The mental action controlling reflexes is of the greatest importance. It is a well-known physiological fact which will be considered later on. First, let us consider the wrist movement. Here I would record in studying the methods used by many dowsers, that some held the rod in different ways from others. On some occasions the rod pointed down when in the presence of water or other substances, but on all these occasions the flexors were the muscles to contract and it was the method of holding the rod that produced the downward movement. When I asked them to hold the rod in another way the movement was always in an upward direction.

Why then should the rod always point up? Why should the rod not point down? Why should the flexors always act and the extensors have no say in the matter at all? There are three important reasons.

*First.* When we hold the rod in the palm of our hands our fingers are flexed over it, already the flexor muscles are slightly contracted, tone of the muscles is therefore increased and because of this, reflex action in these muscles is all the more easily set off. If one sets out, say, to find the presence of a spring without the use of a divining rod, using the hands alone, it is far easier to get the reaction if we slightly flex our fingers rather than keeping them in a more or less extended position.

*Second.* We take the line of least resistance. When we start dowsing, the palms of our hands are practically horizontal, facing upwards, from there our greatest movement is flexion; it is easiest, extension from that position is limited and not comfortable. It is only natural, therefore, that we should think of flexion. I use the word 'think' here particularly, which now brings us to the third reason.

*Third.* The mental action. This is an extremely important action. Most of us in dowsing are waiting for the rod to rise: beginners expect the same to happen; they never think that the rod should point down for it is not comfortable and movement is limited. Yet I say here that dowsing can be done by using the extensors and causing the rod to point down, if we concentrate on the extensor muscles. At one time I used to think that



because the flexors are stronger than the extensors, anything affecting all the muscles equally, flexion would result. Now I know this to be absolutely wrong; we are dealing purely and simply with reflex action. Hence the great importance of the mind, which we will now consider.

#### THE ACTION OF THE MIND

All our reflexes are controlled by the brain. Physiologists have known this for a long time. If the brain had no controlling influence our reflexes would run riot; they would act severely on the slightest stimulation; a slight stroking of the skin would cause groups of muscles to contract spasmodically. The control which the brain exercises is by the will; we can by will power prevent a reflex taking place, a desire to sneeze, for instance, can be checked, a desire to cough can also be checked. Now if any disease or injury cuts off the brain influence, our reflexes then are released so to speak, their action is more powerful and they are more easily stimulated. A man who has had a small cerebral hæmorrhage has all his reflexes exaggerated—we tap him below the kneecap and his leg springs forward far beyond the normal limit; he has what doctors call plus plus knee jerks, the brain influence has been weakened by the hæmorrhage and the reflex thereby released. Now in dowsing if we walk towards a hidden spring we are concentrating on feeling 'something', naturally with our hands outstretched; waiting for the rod to rise we are concentrating on our flexors, and movement takes place there. What we have actually done mentally is to release the reflex for that muscle or group of muscles. One might even say we sensitize that particular muscle.

This then being the case, will any muscle do? The answer is decidedly yes—provided, of course, you have the power to release its reflex. Experimentally, I have found I can use many groups of muscles, or single muscles, for divining purposes; for instance, if I hold my tongue midway between the roof of my mouth and the floor of my mouth, concentrate on it and move in the direction of water, it rises towards the roof. Similarly the jaw muscle, the masseter, can be used in the same way. Again, if we extend the fingers (which puts tone in the extensors) and concentrate on extension while we walk towards water, the extensors will act and the fingers will point down. I find no difficulty in this now. Therefore by concentration (it seems to be the opposite of will power) we can indicate the reflex in any group of muscles we wish.

Here, then, we have before us one of the main reasons why certain people fail to detect the presence of substances. They

cannot mentally release their reflexes and also in many instances they hold the rod so rigid that they contract their extensors as well as their flexors, and so it is impossible for the reflex to act at all.

Like all other reflexes, the stronger the stimulus the greater the reaction, like the movement of retraction caused by something moderately hot and very hot ; thus a poor supply of water will only give a feeble response. I hold that everybody has the power of dowsing if they know how to do it ; it really becomes a matter of training—first to relax the muscles sufficiently to let the reflex occur and secondly to release the reflex by mental action. This second part is by far the most difficult to do ; some can take off their mental control more easily than others and so become good dowsers ; this also explains why some are better than others. An experiment suggested itself to me to test this theory of reflexes and mental control. Why not teach a person who has some cerebral lesion the art of dowsing—a person whose reflexes are already very much released—and note the result ? By good luck this year I came across the very type of case I was looking for. He was a young man who had a slight hæmoplegia on the left side. It was a little cerebral hæmorrhage that had occurred at birth ; he had plus plus knee jerk and plus plus arm reflex. He was very interested and keen to learn divining and gave me his full co-operation. At first I had great difficulty in getting him to relax sufficiently. I made him use his left arm alone, his hand out in front with fingers flexed ; we moved backward and forward over the spring I knew to be there, then suddenly he found he could do it. The reflex action was strong, indeed it was violent, not only did his wrist rise up, but flexion came from the elbow and shoulder and ultimately went into a condition of clonus. It was intensely interesting. Here we had a case of spreading reflex action and the strength was sufficient to produce a clonus, a condition we get in hæmoplegics when we excite their reflexes strongly. Clonus is a rhythmic to-and-fro movement, a jerking—in this case the whole arm was jerking. Here, then, was definite reflex action.

Considering now the movement of the pendulum : is it not a very very slight clonus greatly exaggerated ? a complicated to-and-fro movement which causes the pendulum to gyrate ? I am convinced that it is. There is no doubt that the external ' influence ' or ' rays ' or whatever emanates from the substances we look for, affects our bodies as a whole and we can indicate its presence by reflex action ; whether it excites the muscles directly or through the sympathetic nervous system is without the scope of this article.

Mental effort, to my mind, is exceedingly important. Most dowsers do feel exhausted by practising for a length of time without a break, for the concentration requires a great deal of nervous energy.

To conclude, I would say that mental action therefore seems to me to be the all-important factor, but the reflex itself may even be altered by different substances. Much scientific study is required on this point and a study of the movements of the pendulum would seem to be the way to a solution.

There is no doubt that the more we study the problem of dowsing the more we can see the close association between mind and matter.

---

---

## DOWSING AND ARCHÆOLOGY

By Captain W. H. TRINDER

**H**AD I been asked some time ago whether I thought that archæologists would ever consent to use the services of a dowser in their researches, I should have unhesitatingly said 'No'.

Since then, however, I have come in contact with two archæologists, both of the younger school, who have, quite independently of each other, admitted that their work would be easier if they had some method of telling from the surface whether anything was buried in a tumulus, as this would often save them the expense of unnecessary digging.

I have been fortunate enough to be present at the opening of one or two tumuli, and it is no job to be lightly undertaken. I saw how all the measurements and levels were first taken and the periphery clearly staked out so that the tumulus might be reinstated after the investigations were finished. This entails a fairly skilled knowledge of surveying. In addition, the soil and turves have to be stacked together so that they may be handy for replacement.

I told one of these gentlemen that I thought I could tell him when there was any distinct body present, such as pottery or metal, and he agreed to test me on a tumulus which he had not touched.

I marked two spots where I said there was pottery, and on digging he found in the first spot a small mass of clay which he said was poorly-baked pottery which had reverted to clay. I should have remarked that the rest of the tumulus was shingle.

In the second spot he found broken pottery.

I did not try for metals as he told me that in a tumulus of this particular kind there would be no metal. I am sorry now that I did not try, as he afterwards found pieces of iron which had been buried in a secondary interment above the primary one.

I have given this illustration, as it seems a good example of how trouble might be saved to those on whom we depend for our earliest history of things, and there seems to be no reason why the subject should not be developed until no archæological party would be complete without its dowser. He would be able to trace for them buried cellars under ruins, buried metals in walls or in the ground, tell by the use of the 'serial' numbers the sex of any human bones found, and could, also by the 'serial' numbers, tell to what animals any pieces of bone found had belonged.

There will, no doubt, be the same difficulties in convincing people of what can be done in this way, as always obtains in any new science, but there is no doubt that there is scope for development of a branch of dowsing which may be of enormous use to archæologists.

I advise anyone who thinks of studying this branch of dowsing to go to some museum and take for himself the 'serial' numbers of animal bones, such as have been found in diggings, and of the various sorts of pottery, and make a note of them. He should also practise over the bones of present-day animals. These are easily come by and will serve as a check, as in many instances the bones found in old wells, tumuli, etc., are those of animals such as sheep, fowls, or dogs, which are, of course, the same as those of the present day. The question of distinguishing between the different types of pottery is more difficult and is better done by means of a 'sample', though these are not very easy to get.

Still, only a very small piece of each type is necessary and might be obtained from an archæologist, who would probably be kind enough at the same time to name the various types.

This is only a very rough idea of what may be done in this field, and I put it forward as a field for experiment for any dowsers who wish to enlarge their sphere of action.

May I, however, utter a word of warning, which is this: Let anyone experimenting in this field thoroughly check his own results before offering his services for practical use. There are many people who do not believe in the possibilities of dowsing because they do not understand it and are only too ready to point to any failure as a proof of the inefficiency of this science.

## WATER DIVINING

### II.—What the Diviner Does

By Major C. A. POGSON, M.C.

THE unqualified successes obtained by the better known diviners did not pass unnoticed, and the subject was much investigated by the late Sir William Barrett. Unfortunately he was also deeply interested in psychic matters, and hence investigated the question as largely from that point of view as from any other. I have read many of his researches in this direction, but the fact has again struck me that the shape of the twig was overlooked. In a few cases the twig was entirely dispensed with and hands alone employed, and where this was the case similar movements of the hands have invariably occurred. These movements should alone give rise to a query as to the reason for the employment of the Y-shaped twig. As a result of his investigations, Sir William Barrett definitely proved that water-divining could undoubtedly be done by certain individuals, but he formed the opinion that it had a psychic basis. It is to be regretted that the water-diviner himself has been largely to blame in hindering the furtherance of a scientific knowledge of the peculiarity, if I may call it this. In olden days anything of this description was regarded as witchcraft, as no explanation was forthcoming for it. The fate of those who practised witchcraft was sad, and naturally it was an unfit subject to be investigated by hard-headed men of science. In more recent times, the water-diviner, thinking himself endowed with some wonderful power, was delighted to enshroud himself in mysticism, which is almost as unfavourable a condition of things for any progressive movement as attributing divining to witchcraft.

#### WHAT ACTUALLY HAPPENS

Let us see what actually happens in practice. When setting out to find water a diviner puts out his hands, arms bent. When he walks over a current one of his hands is involuntarily pulled towards the water, i.e. straight downwards in a vertical path. Now suppose he is grasping in his hand a Y-shaped implement, the stalk of the Y in one hand and a branch in the other. It will be recognized that this forms an eccentric, and when one hand wishes to descend vertically it cannot do so but must revolve round the other hand. What then happens to the upheld branch of the Y? That too must turn over. This simple fact has been entirely overlooked and simply because the upheld branch turns

over this has given rise to the very old superstition that certain woods which have an affinity to water must be employed. But this is utter nonsense.

#### WHY DOES IT TURN ?

What makes the branch turn over and why, therefore, a Y-shaped twig has been used having been explained—even although the reason for its use was not understood—the next question which will certainly arise is, ‘What makes one of the hands go down?’ To endeavour to give an explanation of this, I will briefly turn first to another matter. There are on the market certain automatic instruments known as water-finders. The interior mechanism of these is best known to the makers, although it might be mentioned that one of the components is a dial on which is a free-moving needle. Now it is an established fact that when the instrument is set up on a small tripod and placed over a current of water, certain deflections and oscillations are shown by the needle, and that when placed on a site where there is no current, the needle remains steady. From this it may be deduced that there must be some force which the current of water exerts on the highly sensitive mechanism of the instrument. The inventor of one of these instruments, on being interrogated, merely gave as his opinion that it must be the effect of natural electric currents flowing along the water current. Now although it is a known fact that currents of water form the easiest paths of resistance for earth electricity, and consequently electric currents will naturally be found passing along such paths, scientists and engineers will stoutly affirm that there can be no connexion between such currents and the instrument from an electric point of view. As far as the laws of electricity are known, I agree, but what, then, makes the needle move and oscillate on both sides of some mean point, sometimes slowly, and sometimes very fast? During recent times considerable research has been conducted into ‘penetration radiation’ and it has been found that some unknown force does exist, while it has also been demonstrated that water, oil, metals, etc. do possess radio-active properties. I do not propose to enter into any scientific details or technicalities here, but I do wish to emphasize the point that, notwithstanding all that may be said about the possibility or impossibility of any electric or earth magnetic currents being able to affect the instrument, some force generated does cause the needle to move, the instrument being a plain but mute witness to this. Furthermore, it would appear that this force, whatever it may be, is of an alternating character.



## THE BIOMETER

Some years ago an eminent French scientist, Dr. Hippolyte Baraduc, invented a small instrument which he styled the Biometer. As I have already said, I am avoiding technical details, so I will not attempt to describe the appearance of this instrument except to say that it had a dial with a needle attached to it. Two of these instruments were placed side by side, but totally unconnected. The hands were then held out near the instruments, and the needle of one was repelled and the needle of the other was attracted. Dr. Baraduc's theory was that the instrument showed the action of what he termed 'vital current' and that this force, whatever might be its actual nature, is universally present and operates as a current of physical vitality, perpetually flowing with more or less energy through every physical organism. The theory in all its minute detail is exceedingly elaborate and has been described in detail in the doctor's published works. He was engaged in writing another treatise which would have thrown still further light on the subject when he died. In brief, however, his theory was, and his experiments proved that this unknown force or vital current enters at the left hand, circulates through the body, and passes out at the right hand; that is to say, there is an *indrawing* at the left and a *giving out* at the right, thus agreeing with Reichenbach's experiments on the polarity of the human body. The amount of deflections on the needles of the Biometer varied very considerably with different people; in the majority of cases the number of degrees deflected was small, although in a few cases the readings were large. Further, the readings of both instruments were not by any means always the same. For instance, the needle affected by the incoming force might register 10 degrees, and the outgoing force 30 degrees, while with another individual the degree of registration might be reversed, or similar with both instruments. It was upon this variance exhibited by several individuals that Dr. Baraduc was working when he died.

## AN UNKNOWN FORCE

Now, looking at the phenomenon from a layman's point of view, it would appear that in some cases the unknown force was retarded in strength and in others was increased, while in still others it would appear to pass out exactly as it passed in. I might add that these experiments were made in the presence of medical men. Again, it is a known fact that the human body contains electrical energy, as is demonstrated when the operation of brushing the hair in dry weather produces small sparks and

audible crackles, and it is also known that when the muscles are taut or relaxed these electrical energy currents tend either to follow the line of the muscle or to operate transversely across it. Now it is possible that the line of direction of these (for short) bodily currents of electricity may exert some effect on the so-called vital currents already described.

*(To be continued)*

---

## DOWSING AND HORTICULTURE

By T. H. DARLINGTON

I HAVE spent many anxious hours trying to make this article as simple and understandable as possible, but unfortunately the whole thing is so complicated, and unless I know what experience people have had and what tools they use, it is next to impossible to make myself understood. Consequently I have kept to the bare outlines of the process; anybody who is sufficiently interested can make experiments on these lines—they might find some of the minor details will not tally with their own findings, but the reader can rest assured that what I say is not a theory of mine on paper, but the result of several years' experiments which I have proved to be correct in my case. As my living depends on this work, it stands to reason that I could not afford to put these findings into practice unless I was absolutely certain that I would procure the best results.

Several years ago I discovered that I had the gift of telling whether a plant wanted water. I found it out quite accidentally, and as I do about three or four hours' watering with a hose in the summer time every day, I have found all the 'snags' which a person who does not do much watering would probably overlook. I will describe the main details for the reader to try, the after-part will look after itself, but one must be certain of the first essentials. The materials required are several pots containing plants, some wet and some dry, and an ordinary watering-can half filled with water. Prepare yourself by rubbing the hands well together in order to remove any outside interference from the last thing you were locating, then hold the plant in the left hand, looking fixedly at the plant, then grip the watering-can, in the right hand, getting it nicely balanced. Start with a plant that you know wants water, pour the water slowly on the soil; after a few seconds the can will gently turn away to the right; the feeling will be the same as though you were holding a rod

and it was turning over for water. Then leave that plant and try the next. If you are doing it correctly and that particular plant does not want water, you will feel the force pushing the can away. It all depends on your power of divining how great will be the 'force'. With some, it might be barely perceptible, but in any case you *must* persevere. It might take several days before you feel the 'force', or it may only be a few minutes. The thing to keep in one's mind is that it is possible, and is not a theory but a solid fact. I cannot explain all the 'pitfalls'; the main thing is to get started.

If you find the watering-can will move in your hands, you can try another proved experiment. Get a few plants that you want to pot up, sufficient soil to fill them and various small lots of different kinds of manures. For this, you must rely on the sense of touch, so it is advisable to concentrate as much as possible and be alone if possible. First handle the plants, then turn the soil over well with the hands (in the early stages you must use soil you know to be good), relax the muscles of the right hand as much as possible and place it over the first manure. If any is required, the hand will stay there. Place the hand in the manure, and when you have sufficient manure in the hand, a 'force' will gently pull the hand containing the manure over to the soil. Then try the other manures; a gentle 'force' will push you past manures not required. There are heaps of 'snags' in this as well, as I have found to my profound disgust, but the main thing is to concentrate on strengthening this 'force', which all diviners possess in varying degrees of activity.

I would suggest everybody trying this experiment, even if not interested in horticulture, as you will find the same idea will act on human beings. If you concentrate on what you are doing and relax the muscles sufficiently to allow the 'force' to take control, you will find that foods or medicines suitable (and the required quantity) will be gently taken to the mouth. If they are bad for you, the force will take it away to the right.

---

---

## DIVINING MINERALS, OIL AND WATER

By GEO. G. FLEMING

**M**ANY different methods to determine the location of minerals, oil and water and various instruments of all makes and designs are used by dowsers in their search for the treasures of mother earth. There is no hard and fast rule that can be laid down as to the method or type which should be adopted by any individual dowser, most of whom evolve

some method and design of instrument best suited to their particular make-up and requirements. The writer uses a divining rod which rotates or tips down when over the object of search therefor. The following observations may be of service to the dowzers who work the rod in the same way.

#### TYPE OF ROD

In the first place, I use separate rods, or rather instruments built specially for each mineral, oil and gas, or whatever else I happen to be in search of. Each instrument consists of two rods inserted into a wooden end, the whole forming a V shape. The end is made of maple wood, and is  $2\frac{1}{2}$  inches long, 2 inches wide and 1 inch thick; this block is shaped or tapered to make it as light as possible, two holes are bored,  $\frac{3}{16}$  inch diameter, and the same distance from each edge, these holes being set in the end at about 30 degrees. Below these holes and in the centre, another hole is bored,  $\frac{3}{8}$  inch diameter; this hole forms a receptacle for the 'sample', which is in reality a piece of material similar to that for which I am in search. The smaller holes are to receive the ends of the rods, which are celluloid knitting needles about 15 inches long and thick enough to tighten into the  $\frac{3}{16}$ -inch holes.

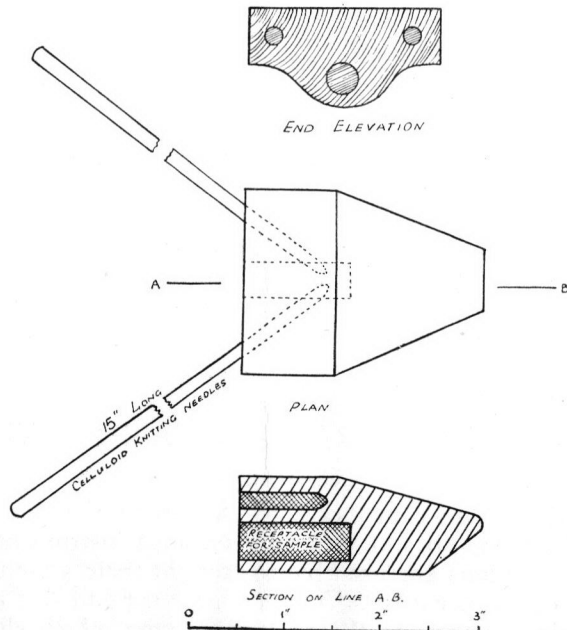

The needles can be purchased for a few pence in any drapery store, and an added advantage is that they can be got any colour desired. This type of rod I find is very smooth and allows even rotation in the hands without jerking. I mark the right-hand rod with a positive mark and never interchange it with the left side ; this is important, as in time the rods become magnetized. As mentioned previously, each rod has a sample of the precious and base metals or whatever else I might be in search of, and the end is coloured to match the rods : the colours used in some instances correspond with those as set out in *The Modern Dowsers*, but they were arrived at by testing the different coloured rods, without samples, on known deposits, the set which responded was noted and samples added and sealed with plastic wood, no metal being used whatever in the construction. I have used this type of instrument for many years and find it very efficient, and having separate rods for the different objects sought eliminates the 'serial' method of determination.

#### MINERAL PROSPECTING (LODE)

The first thing I do on arrival on the property to be prospected, say, for gold, is to take the gold rod, holding it in both hands, palms up and thumbs out, and slowly turn round : if there is gold within a mile or two the rod will tip up immediately my body becomes between the rod and the deposit. In other words, direction is received through the nerves of the spinal column, and the direction is carefully noted and followed, holding the rod as before. Immediately the deposit is intersected, the rod tips down, the width and the line of strike is then worked out and compass bearings taken. Now, the vein or lode may or may not outcrop where first contacted : if it does not, it is followed by using the rod, towards ravines or other points of erosion and invariably one finds the vein matter exposed there ; the dip is then first worked out with the rod and checked with the exposure and the depth estimated at where the vein will carry values ; other mineral rods are tried and the operator can then say definitely if the ore is a complex one or not. Generally it is found that a whole series of veins exist, and if so, these require to be traced and plotted on a map, as also cross veins and faults. Dowsers who specialize in mineral locating should have at least a superficial knowledge of geology whereby they can determine correctly between formation veins and cross or fissure veins : it is at the intersections of these two systems that very rich values are encountered, and again, it is essential that they work out the dip of a vein, for this reason—the emanations which come to the

surface of the ground come at the same angle at which the mineral is dipping. All veins do not dip: some are perpendicular, which of course simplifies matters, but where a vein is not exposed and is dipping, and should the dip not be worked out correctly and supposing a shaft was sunk at the point of contact made with the rod, the vein would be missed altogether. The writer has seen more dowzers fall down under conditions such as these than any other way.

#### OIL AND WATER

Oil prospecting is much simpler because in most oil structures the oil is held up in the sands by hydrostatic pressure and therefore it is very easy to determine the boundaries of the oil sand as this condition makes a very definite line of demarcation. Within the boundaries there is a liability to faults and blank areas. These should be carefully noted and plotted on the map as in mineral locating.

The same method can be applied for direction in respect to oil as that used and explained in connexion with mineral locating, although in oil the boundaries are much more irregular. However, the emanations from the deposits are of the perpendicular variety. There are only two exceptions to this rule known to the writer, viz. the Turner Valley Field, situated in Alberta, Canada, and the Kettleman Hills Field, in California, U.S.A. Both fields are situated on what is termed 'Mountain Structures', the formation having a dip of 70 degrees on the flanks, and the production from the wells in both fields is crude naphtha. Much care has to be exercised under these conditions. Under certain circumstances water which is running in rock fissures may have emanations coming to the surface at the angle at which the fissure may be dipping. In my opinion this is accounted for by the texture of the rock which forms the walls of the fissure.

#### DEPTH

As in other branches of dowsing, the methods of estimating depth vary considerably with the individual operator. I find the unit system is adaptable to all forms of locating. First, I find if the deposit responds to a unit of, say 100, and if so, I allow the rod to go down as often as it will: each time down represents one unit. The unit may be from 1 to 1,000 feet as the case may be, and when the rod turns up, this action means the operator has reached the first sand. On trying again, the rod commences a downward movement. Once more I count as before till the downward action again stops, and keep repeating



till there is no further downward pull. This system gives one the number of sands and their respective depths which may be contained in any structure and which carry oil or water.

Before concluding I would like to pass on a few hints to beginners. Keep a careful record of success and failure and do not be discouraged if you are wrong in your findings occasionally : try to ferret out the cause of the blunder, and when found, rectify it—you will never make that mistake again. Never under any circumstance allow other people to try out your rod. If they must experiment, have a spare one and let them play with it. Try to develop your powers of concentration and observation. It will help you if at some time you have to demonstrate the science of dowsing before sceptics. Practise estimating depth as often as possible by visiting districts which depend on their water supply from underground means : trace the springs to the wells, make your calculation and have the owner check your estimate. In a short time you will find you will be able to tell to an inch the depth the water is encountered. Dowsing is a progressive science, the more you practise the more you will advance in knowledge. Study as much geology as you can, but make your geological theories conform to the dictates of the rod and remember the dowser is usually brought in when all other means fail. It is up to you.

---

## CORRESPONDENCE

*Garrallan, Cowra, New South Wales,  
October 30th, 1933.*

DEAR SIR,

I have been carrying on a certain amount of independent investigation of dowsing for some years and with a reasonable amount of success. . . . Strangely enough, neither 'baguettes' nor 'pendules' will give any results in my hands, presumably because the reactions produced do not affect the motor-nerves and hence the muscles, at all. The instrument I use is merely

a piece of wire, iron, steel, or copper, 10-14 gauge quite heavy enough, shaped thus :

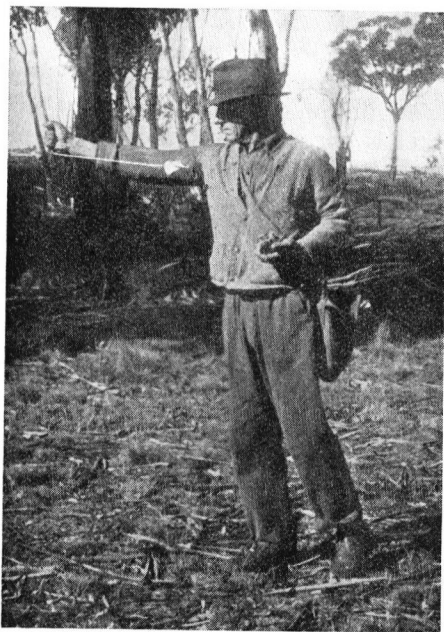

Over the object, the wire swings in towards the centre of the body.

[The paper is attached to the wire to make it easily visible.]

I hold the short end in one hand with the longer end projecting forward and the short end downward. The point A will then be attracted to any wall (or line) of force given off, say, by a stream of water, pool or body, etc., according to the material sought for. The point A will follow all the convolutions of a subterranean water-flow, indicate where there are pools or accumulations in this flow, etc., etc. Again the point A will be drawn in the direction of a stream, pool, etc., from long distances, just as a compass needle is drawn to the north, so that there is no need to traverse much ground as one can follow the point direct to the site.

For example, if I go on to an area of country in which it is desired to find water, when I alight from whatever conveyance

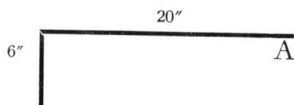

I have travelled in, I merely have the question in my mind, 'Where is the nearest pool (stream or spring)?' And usually in a very brief space of time the wire turns in a direction and I follow the point until it turns in to a centre, indicating that the site is reached. The rod may take me many hundreds of yards in this way. If I wish then to examine the site in detail, I usually turn the rod up the opposite way (short end upwards). The point A swings in towards the centre of my body when I am over the object, as though some form of induced magnetism had been set up in the body which attracted the point. The action is the same for each hand. When tracing a stream I sometimes use a wire in each hand when the points will each follow one side of the stream. . . .

For tuning in to different materials the method of carrying a sample can be used, but I usually employ a colour method which I have evolved, or else merely have the thought of what I am seeking in my mind—a mental adjustment or tuning.

In using colour the idea was to reverse the use of the spectrum, i.e. use the colours when the proper ones had been discovered, to trace the metals, and I think that I have achieved a certain amount of success through a trial and error method. I carried it out with the assistance of other diviners who did not know what they were looking for, but were content to gaze at certain combinations of colours while moving along holding a rod or forked twig, whichever they used.

I placed samples of various materials one at a time on a shelf above a doorway, as the rays, waves or whatever the force may be called, are given off downwards as well as upwards. I should be glad if you would be so good as to test some of these combinations in this way: red and blue=petroleum, red alone appears to act for the residues of petroleum, while red and blue cause a reaction to actual oil. Orange=antimony; yellow=silica; green=iron; blue=water; indigo=aluminium; violet=gold; red, yellow, black=copper; red, white, blue=silver; blue, green=tin; orange, green, blue=sulphur; black, red, yellow, blue=granite; blue, indigo=salt water; red, green, blue=salt (sod. chlor.).

I have been using my methods for the location of gold and the results so far are encouraging and lead me to think that when I can have certain sites thoroughly tested, if these prove to be all that I believe them to be, then New South Wales contains all that is necessary to lift the foreign debts of the Empire. . . .

Yours faithfully,

H. O. BUSBY.

VICTORIA, B.C.

November 9th, 1933.

DEAR COLONEL BELL,

I think you may be interested in the enclosed testimonial about finding water from maps.

As you know I am very keen on this form of divining and think it has a wonderful future before it, especially in a huge country like this, where so much of it is inaccessible except to the most hardy and well-seasoned pioneer prospector. This of course refers chiefly to metal finding. . . .

I do not know the province of Alberta at all, nor am I acquainted with Mrs. Parlby personally, but was given an introduction to her through a mutual acquaintance.

I offered to find her water on a map as she needed it badly for her farm, and I wanted to make a test map out of it for myself. The map was drawn accurately to scale and I marked the meeting place of three streams on it. I told her she must dig on the *exact* spot marked and the result was most satisfactory. . . .

I am a great believer in the Pogson Motorscope and have used the Pogson method for several years. . . .

The 'Bishop's rule' seems to be the same thing as The First Field of Force spoken of in Henri Mager's book, but the 'Area of Emanation' spoken of in the Pogson method (page 30, Art of Water Finding, by M. E. Pogson) does not agree with this. I wonder if any of your members have fathomed this?

It would be very interesting if, through the mediumship of your journal, diviners would report as to the effect samples have on them.

With me, all effect from gold is cancelled on a map when holding gold in my hand; but on the other hand I can use a rod containing a gold sample to find the gold on the ground; or I seem to be able to divine equally well without a sample. Also some people strongly advocate green for gold-divining and others violet. I find one as good as the other, which has rather shaken my faith in colours. . . .

Wishing the British Society of Dowsers the very greatest success.

Yours sincerely,

EVELYN M. PENROSE.

MANADON FARM,  
ALEX,  
ALBERTA.

July 9<sup>th</sup>, 1933.

DEAR MISS PENROSE,

I enclose cheque in payment of your fee for finding water by map.

The well is now dug on the exact spot you marked on the map and the water is there.

The well is 40 feet and the first stream came in at 20 feet. They went past that and came to the second stream at 40 feet, when the water came in so fast they could go no further and so were unable to confirm the third stream.

The water is now 28 feet and still rising.

We are much interested in this method of divining water from a map of a place hundreds of miles away and think it a most remarkable gift.

Yours sincerely,

IRENE PARLBY.

[Mrs. Irene Parlby is a Minister (without portfolio) in the Alberta Parliament. She is not a personal acquaintance, and I do not know the province of Alberta at all. Alex is six or seven hundred miles from Victoria, B.C.—E. M. PENROSE.]

---

---

## REVIEWS

*Investigación de aguas subterráneas* by Bartolomé Darder Pericás.  
Salvat : Barcelona 1932.

Señor Pericás' work is a model of careful documentation with the object of furthering the cause of water-divining for agricultural purposes. His conclusions must carry the more weight in as much as they are the considered judgment of a converted sceptic.

In 500 pages he has collated and sifted evidence from the writings and experiments of enthusiasts on the Continent and in America.

It is perhaps significant that he makes so little reference to operations in England, although many English works are listed in the extensive bibliography at the end of the volume.

He wisely lays a sure foundation for his deductions by devoting more than the first half of his book to the origin of subterranean water as revealed by geology and stratification; hence the tracing of the final deposit of rain in the form of sub-soil reservoirs giving rise to springs, wells and artesian sources of water.

Not unnaturally his references are mainly to his own country. But considering that his work is *prima facie* published for the benefit of agriculturists he perhaps, by devoting only one page to the subject, hardly lays sufficient stress on the great influence of forests in the conservation of rain-water once it has reached the earth. The question of whether forests actually increase precipitation from the clouds is still a moot point. But the scientific world now definitely accepts the view that forests store up the rain-water and prevent its rapid disappearance through evaporation. Most of Spain could produce and maintain forests of some kind. The result of a general afforestation would be that the sub-soil water level would be raised (and the surface-depth of wells reduced) to the economic advantage of cultivators, the small rivers would not dry up in the hot weather, and in the rainy season roads and railways would not be periodically damaged by burst culverts.

The second portion of the volume deals with the theory and practice of water-divining and is mainly of a somewhat technical nature. A generous provision of illustrations and graphs (of which there are 272) helps the uninstructed reader to follow the impartial consideration of the arguments for and against each theory investigated. The logical Latin mind is apparent in the rejection of anything that will not pass the test of accurate observation and clear thought. Señor Pericás is scrupulously fair to those who differ from him, but he has little use for unscientific Zahoríes (Arabic: literally 'diviners of hidden things')—the equivalent perhaps of our old-fashioned 'Dowsers'.

He traces back the practice of the art to almost remote antiquity, and claims that the gift of sensitiveness to subterranean objects (water, metals, etc.) is very widely distributed, putting the proportion of those endowed in a greater or less degree at over 70 per cent.

Two requisites, he maintains, are essential for reliability in results—a good grounding in geology and absolute concentration while at work.

Nearly all substances are rhabdoactive (fr. the Gk. *ῥάβδος*, a rod)—but it is curious that water responds only when it is in motion; still water has no effect on the operator.

The theory of Mager as to the efficacy of rhabdical colours and spectra is not accepted, as his conclusions are considered to be dogmatic and his experiments lack the support of detailed information.

The author carried out a number of experiments to enable him to formulate a system by which quantity and depth of water could be accurately predicted.



He found that the lifting power of the rod bore a relation to the volume of water in the stream under examination and so by observing the limiting weight which the rod could lift on a known flow of water was able in some cases to work out a formula embodying the relation between weight lifted and flow.

Further, by inserting small lumps of lead at various depths in the sides of wells constructed in different soils, he was able to arrive at the relation between the depth as indicated by the rod in a certain soil and the actual depth, and plotted the results on graphs.

The author seems sceptical as to reliability of results either in the calculation of water pressure or in the investigation of its potability by the use of differently coloured rods. Still less does he accept the view that the sex of eggs may be determined by means of the pendulum. But the latter, in conjunction with the compass, in the hands of Henri Vicomte de France, has proved a trustworthy means of ascertaining accurately the lie of not only moving water (and even the direction of its current), but also the presence of many other rhabdoactive substances. Nevertheless, Señor Pericás considers that the pendulum is likely to be influenced by suggestion and for that reason he has of late years abandoned its use. He submits that there is no question of the fact that the rod is actually moved by (emanations from) the presence of objects in the soil. Reflex or muscular action on the part of the operator he rejects summarily, as also any theories based on magical or psychical causes.

After weighing and sifting every suggestion or theory available, whether fantastic or scientific, Señor Pericás comes to the conclusion that the phenomena are due to radiation of an electromagnetic nature. Yet he freely admits that the science of divining is still in an embryonic stage, but he holds that material enlightenment is probably approaching. Water-finding, he maintains, is merely a minor issue (though a practical utilization) of the science of rhabdomancy. He himself, in spite of every possible care and precaution, has frequently met with ill-success—mainly in distinguishing between water and other rhabdoactive substances—e.g. sands and clays.

A point that should always be borne in mind is the possibility of the rhabdomantic emanations not rising vertically. They may be subject to deviation, so that they reach the surface at some lateral distance from the deposits.

By his masterly and impartial exposition of rhabdomancy Señor Pericás has rendered undoubted service equally to the ignoramus and the expert.

F.C.-B.

*Bulletin de l'Association des Amis de la Radiesthésie.*

*The atmospheric electric field and rhabdic phenomena*, p. 279 :

Report to International Congress by Cavaliere Alberto de Vita. Experiments on discharge of negatively charged electroscopes and dependence of rate on many factors including position, position of sun, atmospheric conditions, etc. Geophysical methods are now well established for the localization of many minerals, radioactive and otherwise. These investigations are parallel with those by diviner and each assists the other. The report has much detailed information.

*Report on Geology and Geophysics* by Henry de France, p. 291 :

Since de Vita's apparatus now confirms the diviner's work, many investigations of minerals have been made and the results published in *La Chronique des Sourciers* and in *Le Sourcier Moderne*.

*The Diviner and Agriculture* by M. Larvaron, p. 295 :

The study of the soil covers the constituents both mineral and living. The study of soils and plants shows that the fields produced by each should be identical or nearly so.

*Lecture* by M. Joseph Treyve, p. 299 :

He works on maps and plans and can give depth and quality of springs. He applies the pendulum also for drainage problems, also for selection of animals, birds, etc., as well as grain and soils.

*The Medical Pendulum* by M. Pitois (Engineer), p. 305 :

Description of a case.

*The Congress : Note on Work of M. Turenne*, p. 308 :

The wavelengths of rays from various sources is discussed.

*Note by Armand Viré*, p. 310 :

The journal *Vu* has asked for an experiment. (The July number was specially devoted to gold.) An ingot of gold was buried in a field of many acres. The test was made in the forest of St. Germain. Many members assisted, each using his own method. Points were determined, the first at about one yard, the second at about one yard, others up to six yards. The result was considered to be a real success.

*Conference on Radiation-Perception* at Lille on June 28th, by Ch. Vincent, p. 318 :

Lecture by Dr. Le Prince describing work with the radiocampimeter invented by Larvaron. He advised an attitude that did not claim too much and especially avoided definite claims in medicine.

*Radiation-Perception Abroad* by D. Lecouffe, p. 321 :

In Germany, Dr. Oppwald compared results of different kinds of mineral investigation and said that diviners could work beyond the powers of geophysicists.

In Italy, Dr. Cazzamali has stated that the rhabdical phenomena are due to an abnormal activity of the human brain. He employs a cage of metal impenetrable to all rays and insulated, with his instruments inside. A normal person produces no effect on these, but a 'medium' produces strong reaction. Details of system of experiment are given.

*Application of Radiation-Perception to Agriculture* by Hector Mellin,

p. 343 :

Plants and seeds have a radiation direction corresponding with that of the soil in which they are used. Prof. Larvaron has investigated this. His rod turns north for lime, east for silica, south for clay, and west for humus. Mixtures will take intermediate positions. Fertilizers also show directional effects. Grains and other seeds also. With any given soil the fertilizers and seeds can be suited. This study will assist in the development of scientific agriculture.

*Diviners and Medicine* by Dr. A. Le Prince, p. 349 :

Doctors and medical journals are now considering the matter seriously. An apparatus which is quite unaffected by suggestion is most important to measure human radiation. Diagnosis from observations on the pendulum and also from photographs and writing should be studied. Investigations may be made also on the bodily products. The article is very full of interesting detail.

*Remarks* by Dr. Gaudichard, p. 364 :

Doctors are hostile to radiation-perception when badly used. The Institute Phytothérapique uses the methods of Abbés Bouly and Mermet with great success. The best results will be obtained when doctors themselves use these methods.

*Determination of Magnetic Field of Person from Urine* by M. Lesourd,

p. 365 :

There are marked differences between samples from healthy and sick persons.

*The Problem of reading from Plans* by Armand Viré, p. 368 :

The practice is doubted even among diviners and with some reason, as it has failed on occasion under test. The results of a number of readers on maps of which all the details were known to the judges were not satisfactory.

*Remarks* by M. L. de la Bastide, p. 376 :

He maintained that the reading of plans is a fact. The reader must be in a really receptive condition and his work must be habitual. Also the reader should be trained in his subject.

*Remarks* by M. Mazières, p. 378 :

It is most important in all such observations to avoid any interference from all extraneous radiations, human or otherwise.

*Apparatus for Protection from Harmful Telluric Rays* by Lt.-Col. Moreau, p. 380 :

Remarks on the experiments by Lakhowsky on pelargonium.

*Apparatus to determine Depth* by Commandant Coste, p. 381 :

Either for water, metals or minerals. The magnet or electromagnet is placed over the sample (gold) with paper between. The pendulum will then gyrate in one direction if moved away at right angles until a certain point when oscillation will begin. This distance equals the depth.

*Application of Radiation-Perception to Hunting* by M. de la Bastide, p. 383 :

The rod or pendulum behaves differently for different animals and will also indicate the direction in which they have gone. It requires practice to determine when the animal left its position. It may be that the palæolithic artefact of reindeer horn known as ' bâton de commandement ' was used as a divining rod to seek out reindeer.

*The Day at Haute-Isle* by Spectator, p. 387 :

A very well illustrated article showing ancient troglodytic village and a remarkable subterranean church of the seventeenth century. All families but one have left the village. To prevent destruction, Dr. Gaudichard purchased the site some years ago, when a house was erected for the training of young diviners. Many old coins from Charlemagne onwards have been found. They have impregnated the soil so much as to give subsequent reaction there.

Cavaliere de Vita demonstrated his apparatus with thermionic valves. It is independent of special knowledge by the user. It is now only necessary to make it selective.

M. Larvaron showed his apparatus for depth, which neutralizes emitted electro-magnetic waves. His radiocampimeter determines the wave length of the human wave.

M. Lakhowsky showed his apparatus which consists of a series of concentric vibrators with a large range combined with observing instruments.

*An Original Method* by G. Edouard, p. 406 :

M. and Mme Meynaud are members of the *Association*. It is Mme Meynaud who is the medium; her husband acts in sympathy with her, recording and translating the results.

Mme appears able to see the object sought and has done so to a depth of 389 feet as certified by Abbé Mermet. She was very tired after this effort. This lady appears to be extraordinarily sensitive to all kinds of radiations; the great difficulty is to translate and interpret them so as to get consistent results. The work is carried out also with rod or pendulum, with most satisfactory results.